

ROHS

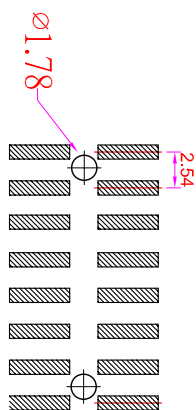
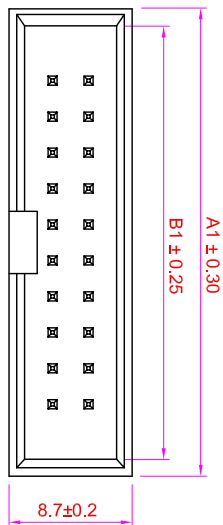

Recommended
P.C. Board Hole Layout

Specifications
 Current Rating : 3 Amps
 Insulator Resistance : 1000 Megohms min.
 Contact Resistance : 20 m ohms max.
 Dielectric Withstanding : AC 600V
 Operating Temperature : -40°C ~ +105°C
 Contact Material : Brass
 Insulator Material : Polyester, UL 94V-0 P/Nylon-6T
 Contact Plated : See Option
 Standard: Full Gold Flash

Order Information

BHAA - M 0 XX - X X XX - X X - X

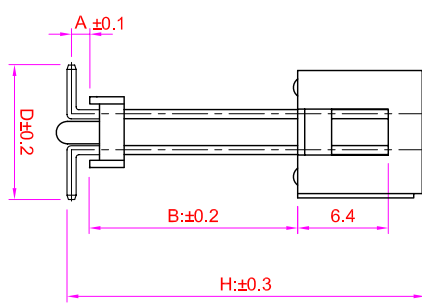
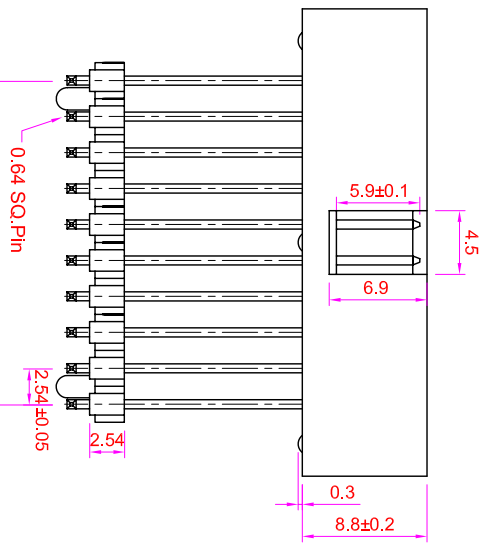

Serial No. _____
 Terminal Type _____
 M : SMD Type _____
 No. of Contacts _____
 Post Option _____
 0 : Without Post _____
 1 : With Post _____
 Terminal Option _____
 1 : A:XXmm , B: XXmm, D: XXmm
 H: XXmm _____
 Contact Plated _____

Cap Option _____
 B : Blank (No Cap)
 P : Plastic Cap

Packing Method _____
 A : Tray _____
 T : Tube _____
 Insulator Option _____
 N : Nylon-6T

CONTACTS	DIMENSION			CONTACTS	DIMENSION		
	A1	B1	C1		A1	B1	C1
10P	20.32	17.92	10.16	34P	50.80	48.40	40.64
14P	25.40	23.00	15.24	40P	58.42	56.02	48.26
16P	27.94	25.54	17.78	50P	71.12	68.72	60.96
20P	33.02	30.62	22.86	60P	83.82	81.42	73.66
24P	38.10	35.70	27.94	64P	88.90	86.50	78.74
26P	40.64	38.24	30.48				
30P	45.72	43.32	35.56				

0.64 SQ.Pin
C1 ± 0.2
2.54 ± 0.05
2.54

GENERAL TOLERANCE		單位 (UNIT)		料號 (PART NO.)		圖號 (DWG NO.)	
X. ± 0.50	X. ° ± 5°	mm		BHAA-M0XX-XXXX-XX	BHAA-M0XX	比例 (SCALE)	Free
.X ± 0.20	.X ° ± 2°		審核 (APPROVAL)			圖面 (DRAWN)	1/1
.XX ± 0.10	.XX ° ± 1°	Alice	料號 (CHECKED)	Mary	Fen-Fen	圖號 (REV.)	B
DATE: 2011/01/12	SSJ					圖號 (REV.)	

名稱 (TITLE):
 Box Header P2.54mm
 Elevated Story / SMD Type

五允企業有限公司
 IO PARTS Enterprise Co., Ltd.

1 2 3 4 5 6 7 8 9 10 11 12